

- OPERATING TEMPERATURE: -55°C TO 105°C.
- MATERIAL: HOUSING, NYLON 6/6, UL 94V-0, BLACK CONTACT, 0.30 [.012] THICK COPPER ALLOY
- FINISH: BRIGHT TIN-LEAD PLATE 0.00203-0.00508 [.000080-.000200"] THICK OR MATTE WHISKER MITIGATED TIN 0.00203 [.000080] MIN THICKNESS OVER NICKEL UNDERPLATE.
- LUBRICATED WITH AMP ANTI-FRETTING LUBRICANT.
- IDENTIFICATION NUMBER FOR FIRST CIRCUIT.
- WIRE GAUGE IDENTIFICATION
- DIMENSIONS IN BRACKETS ARE IN INCHES.
- CONTACT MUST ACCEPT 1.14±0.03 [.045±.001] SQUARE POST AND REMAINED LOCKED IN POSITION.

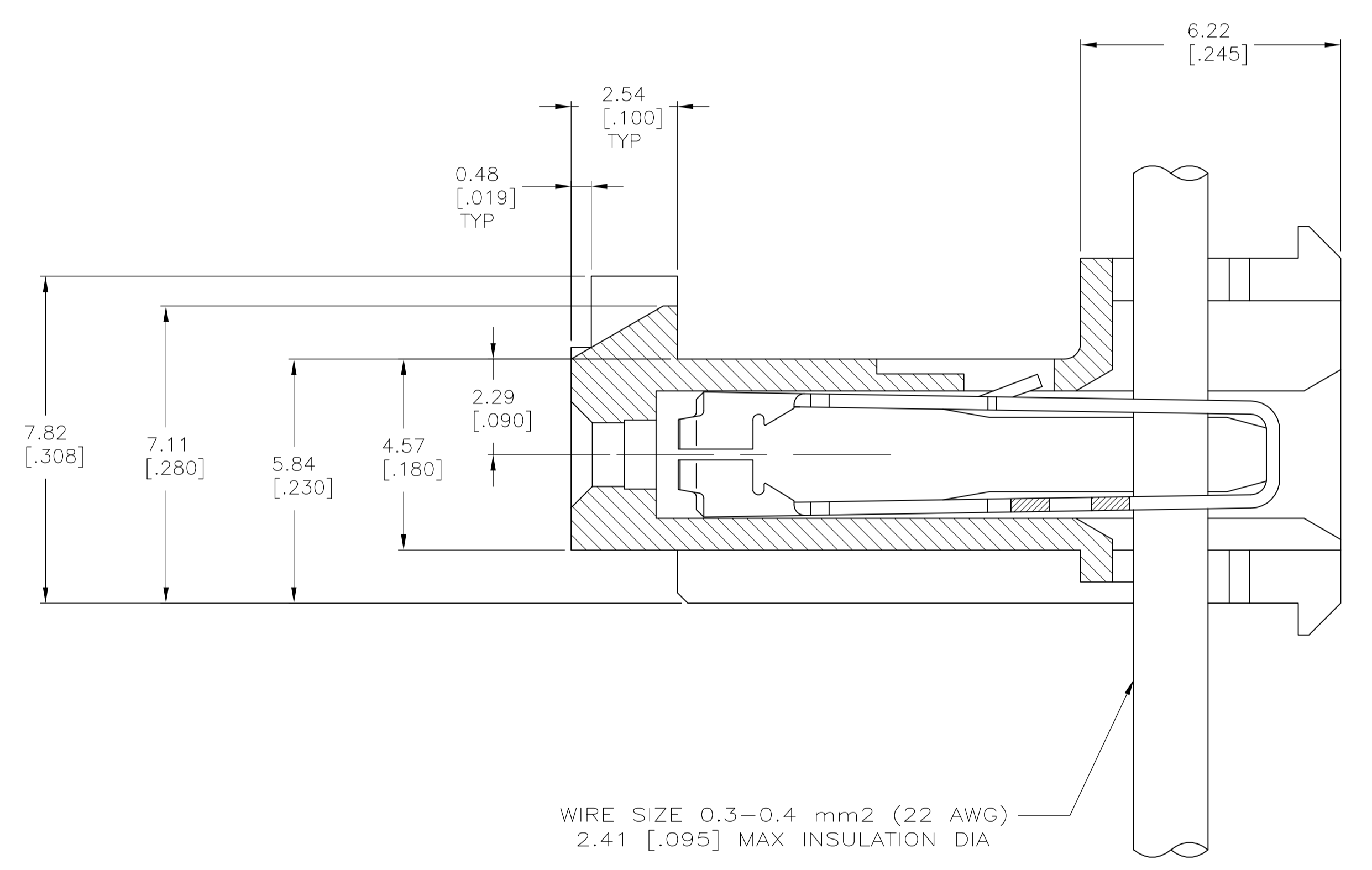

TIN	47.55±0.30	[1.872±.012]	12	4-644389-2
TIN	43.59±0.30	[1.716±.012]	11	4-644389-1
TIN	39.62±0.30	[1.560±.012]	10	4-644389-0
TIN	35.66±0.30	[1.404±.012]	9	3-644389-9
TIN	31.70±0.30	[1.248±.012]	8	3-644389-8
TIN	27.74±0.30	[1.092±.012]	7	3-644389-7
TIN	23.77±0.30	[.936±.012]	6	3-644389-6
TIN	19.81±0.30	[.780±.012]	5	3-644389-5
TIN	15.85±0.15	[.624±.006]	4	3-644389-4
TIN	11.89±0.15	[.468±.006]	3	3-644389-3
TIN	7.92±0.15	[.312±.006]	2	3-644389-2
FINISH	A		NO OF CKTS	PART NO

TIN-LEAD	47.55±0.30	[1.872±.012]	12	1-644389-2
TIN-LEAD	43.59±0.30	[1.716±.012]	11	1-644389-1
TIN-LEAD	39.62±0.30	[1.560±.012]	10	1-644389-0
TIN-LEAD	35.66±0.30	[1.404±.012]	9	644389-9
TIN-LEAD	31.70±0.30	[1.248±.012]	8	644389-8
TIN-LEAD	27.74±0.30	[1.092±.012]	7	644389-7
TIN-LEAD	23.77±0.30	[.936±.012]	6	644389-6
TIN-LEAD	19.81±0.30	[.780±.012]	5	644389-5
TIN-LEAD	15.85±0.15	[.624±.006]	4	644389-4
TIN-LEAD	11.89±0.15	[.468±.006]	3	644389-3
TIN-LEAD	7.92±0.15	[.312±.006]	2	644389-2
FINISH	A		NO OF CKTS	PART NO

METRIC

THIS DRAWING IS A CONTROLLED DOCUMENT.

DIMENSIONS: mm [INCHES]	TOLERANCES UNLESS OTHERWISE SPECIFIED:	DIN C. MARTIN 23APR90	Tyco Electronics Corporation Harrisburg, Pa 17105-3608
0 PLC ± -	1 PLC ± -	244FR90	NAME
2 PLC ± -	3 PLC ± 0.13(.005)	244FR90	MTA-156 CONNECTOR ASSEMBLY, QUAD, 22 AWG, FEED THRU, WITH LOCKING RAMP, WITH POLARIZING TAB
4 PLC ± -	ANGLES ± -	APVD G MILLER	PRODUCT SPEC
		108-1219	APPLICATION SPEC
		114-1048	SIZE
		WEIGHT	CAGE CODE DRAWING NO
			A1 00779 C=644389
			RESTRICTED TO
			CUSTOMER DRAWING

SCALE 10:1 SHEET 1 OF 1 REV E